

CUSTOMER:

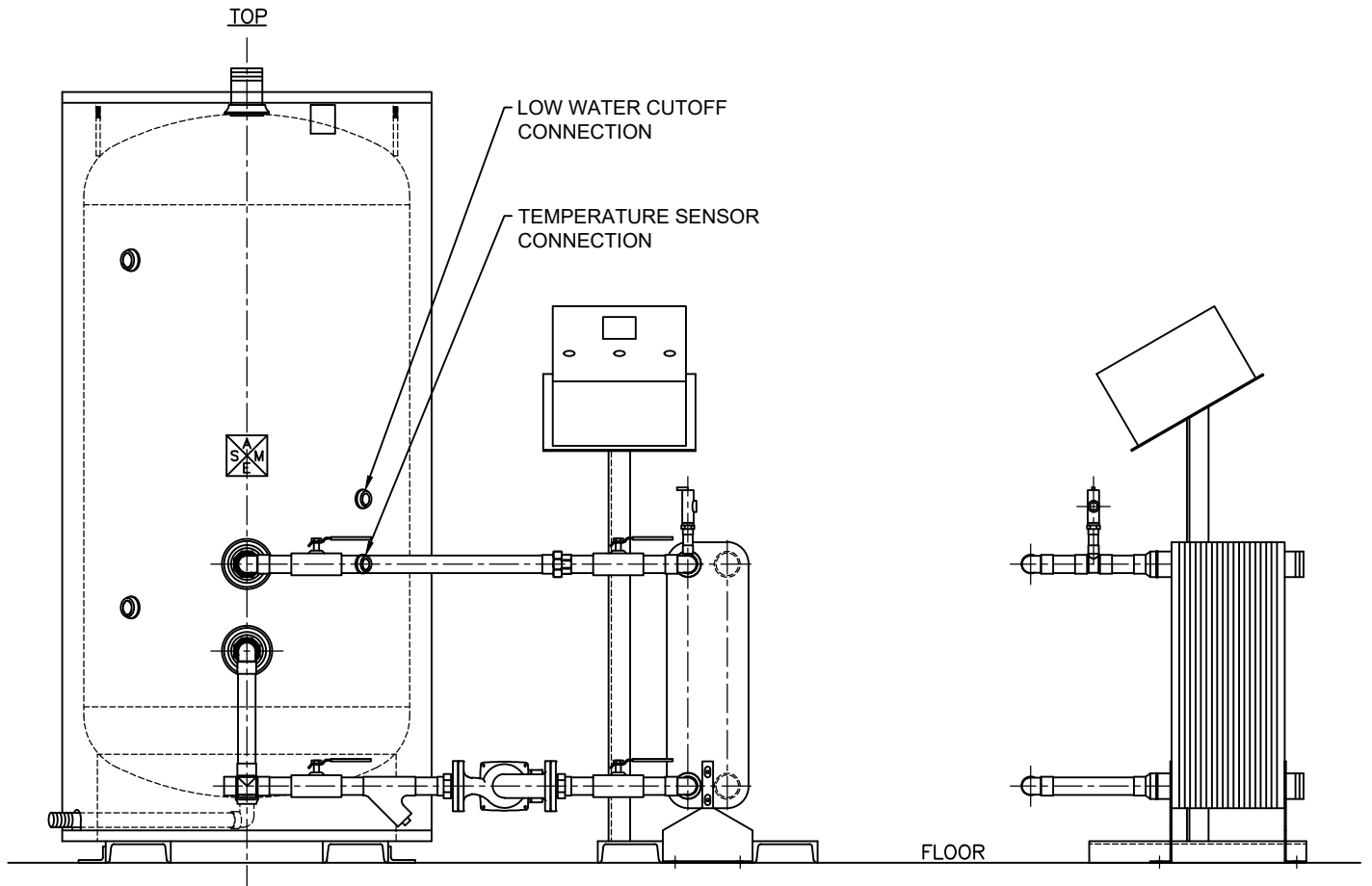
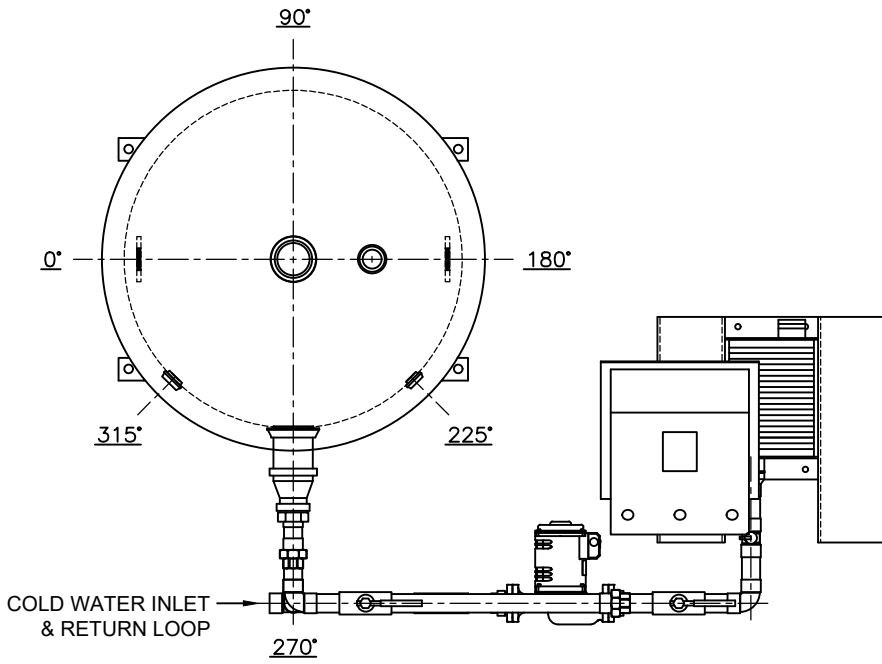

THIS DWG HAS BEEN FURNISHED BY NILES STEEL TANK CO. THE INFORMATION AND KNOW HOW THEREON MAY NOT BE USED NOR THE DWG REPRODUCED WITHOUT THE WRITTEN PERMISSION OF NILES STEEL TANK CO. ALL REPRODUCTION IN WHOLE OR IN PART, INCLUDING VENDORS' SHOP DWGS SHALL BEAR OR REFER TO THIS STAMP.

TANK W/ PLATE HEAT EXCHANGER

QUOTE NUMBER:	DRAWN BY: CJS 6/26/2024	APPROVED BY:
DWG. NUMBER	SCALE NONE	REV. A



1701 Terminal Road
Niles, Michigan 49120
Ph: (269) 683-1910
Fax: (269) 683-1953
email: info@nilesst.com