



# FBZ™

## Electric Steam Boiler

1500 – 3000 kW

- ▶ Zero Scope-1 Emissions
- ▶ High Steam Quality
- ▶ Intuitive Touchscreen Control



### Standard Features

- ✓ Incolloy 800 sheathed elements
- ✓ 100kA SCCR Rating\*
- ✓ ASME Section I or IV
- ✓ cULus-834
- ✓ CSD-1
- ✓ SCR
- ✓ Modbus ready; BACnet capable

FBZ boilers provide reliable, emissions-free operation for environmental sustainability. Equipped with industry-leading features as standard, FBZ boilers exceed expectations in large-scale electric applications.

#### ALL MODELS:

5,500 – 10,500 lb/hr Output F&A 212°F  
ASME Section I and IV Designs



*\*With appropriate fused disconnects installed upstream of unit*

# ADVANCED TOUCHSCREEN

- ▶ 5.7" Color Touchscreen
- ▶ Standard I/O
- ▶ Dedicated BMS Modbus
  - Other Integration Options Available
- Dedicated Outputs for Element Staging
- Individual Input Monitoring for Safety Devices with Alarm Annunciation



## SPECIFICATIONS & DIMENSIONS

MODEL		FBZ-1500	FBZ-2000	FBZ-2500	FBZ-3000
<b>SPECIFICATIONS</b>					
Unit Size	kW	1,500	2,000	2,500	3,000
Steam Output	LBS/HR	5,250	7,000	8,750	10,500
Output	BTU/HR	511,8000	6,824,000	8,530,000	10,236,000
Water Capacity	GAL	1,026	1,026	1,320	1,320
<b>ELECTRICAL (FLA)</b>					
480/60/3	AMPS	1,814	2,418	3,023	3,627
600/60/3	AMPS	1,451	1,935	2,418	2,902
<b>DIMENSIONS</b>					
(A) Height w/o Trim	IN	91 1/4	91 1/4	91 1/4	91 1/4
(B) Width	IN	172 3/4	172 3/4	204 3/4	204 3/4
(C) Depth	IN	92 3/16	92-3/16	92 3/16	92 3/16
(D) Element Pull Clearance	IN	53	53	53	53
<b>WEIGHTS</b>					
Shipping Weight	LBS	11,790	11,790	13,650	14,550
Operating Weight	LBS	18,020	18,020	20,195	22,680

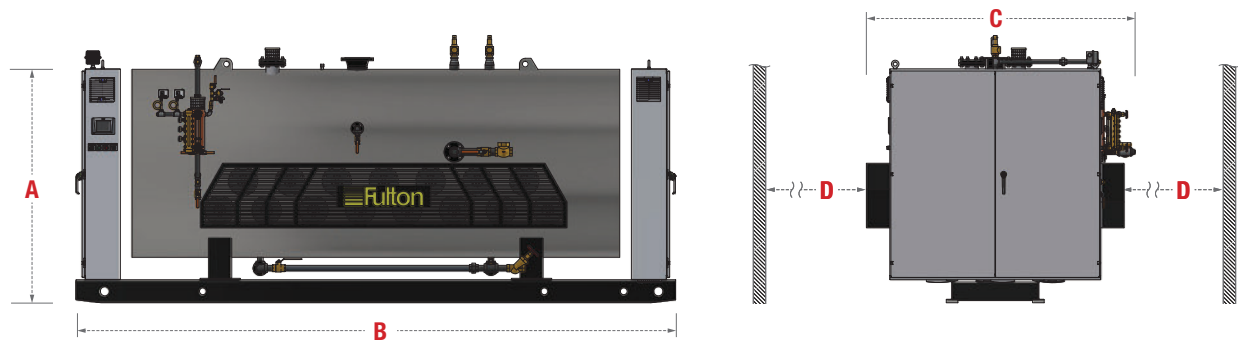

NOTE: Specifications and dimensions are approximate and for reference only. Fulton practices continuous product improvement and reserves the right to change specifications and/or dimensions without notice.



Call: (315) 298-5121

972 Centerville Road  
Pulaski, NY 13142



[fulton.com/fbz](http://fulton.com/fbz)

Drawings & documentation available online

FBZ-1500-3000\_BROCHURE\_240626

