

# JB(X) Series Burners

**Efficient, Reliable, Safe Solutions For  
Cast Iron, Firetube, Firebox, Watertube  
And Process Applications**



10 BHP to 300 BHP Range

## Benefits Of The JB And JBX Series Burners

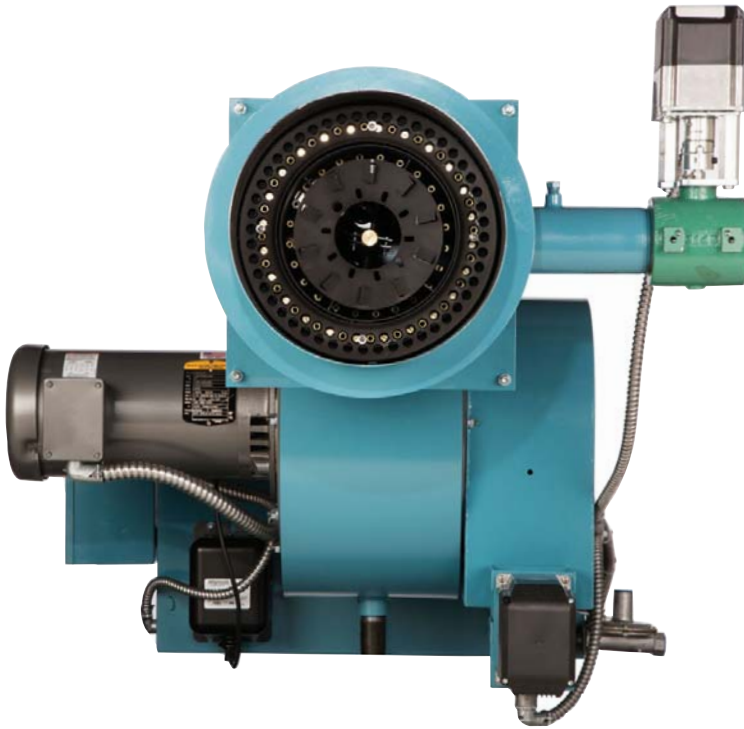

Webster JB(X) series burners offer years of dependable and efficient operation. Designed with ease of serviceability in mind, Webster burners are equipped with a wide variety of the latest control and technology options available. When combined with the patented Webster Temp A Trim control system, the JB(X) burner is by far the most efficient option in the industry.

Versatility and flexibility are prime considerations in the

Webster JB(X) series design. JB(X) series units can be adapted to fire in most any furnace configuration or combustion environment, and Webster has years of proven experience firing a multitude of fuels including: Natural, LP, and Digester gas, No.2 through No. 6 oil, and other more exotic fuels.

Webster JB(X) burners are completely factory wired, assembled, and tested so they come to you ready for installation and connection to fuel and electrical supplies. Typical JB(X) series burners are installed and ready for start-up in a minimal amount of time, saving valuable time and money at your installation.

When it comes to low emission requirements, Webster should be your choice. The JB(X) series burner offers optional low NO<sub>x</sub> configurations. Depending on the application, the JB(X) is available with and without Induced Flue Gas Recirculation for 30ppm requirements. Webster has been providing low emission units for more than 25 years and understands what it takes to meet your compliance requirements.

## JB and JBX Features

### Versatile

- Available in multiple housing and control panel configurations
- Fires multiple fuels
- Designed for all types of boilers, heaters and furnaces
- Proven performance in all types of applications

### Reliable

- Outstanding flame stability
- High combustion efficiency
- Designed for ease of service
- Quiet operation
- UL & ULC Listed

### Adaptable

- Standard or inverted housing
- Burner mounted or remote control panels
- Standard or low NOx designs available

### Efficient

- Linkageless control options
- Add Temp A Trim for most efficient operation and quick payback



**Webster Combustion has the best lead times in the industry. To configure the perfect JB(X) burner for your application and obtain current scheduling information, contact Webster or visit [www.webstercombustion.com](http://www.webstercombustion.com) to locate a sales office in your area.**

## JB(X) Series Maximum Input Capacity Ratings

Burner Model	Min Req'd Gas Press	Std Gas Train Size	Max Firing Rate (MBH) Std	Max Firing Rate (MBH) w/FGR	Fan Motor HP
JB(X)1*-02	6"wc	1"	1000	800	1/4
JB(X)1*-03	8"wc	1-1/4"	1500	1200	1/3
JB(X)1*-05	8"wc	1-1/2"	2100	1680	1/2
JB(X)1*-07	11"wc	1-1/2"	2500	2000	3/4
JB(X)2*-07	13"wc	1-1/2"	2800	2240	3/4
JB(X)2*-10	14"wc	2"	3500	2800	1
JB(X)2*-15	14"wc	2"	3500	2800	1-1/2
JB(X)2*-20	14"wc	2"	4200	3360	2
JB(X)2*-30	14"wc	2-1/2"	5300	4240	3
JB(X)2*-50	18"wc	2-1/2"	6000	4800	5
JB(X)3*-30	1 psig	2-1/2"	6300	5040	3
JB(X)3*-50	1 psig	3"	8300	6640	5
JB(X)3*-75	1 psig	3"	10,500	8400	7-1/2
JB(X)3*-100	1.5 psig	3"	12,600	10,080	10

\* Can be "G" (Gas), "O" (Oil) or "C" (Combination Gas/Oil)

## JB(X) Series Typical Dimensions (Inches)

Model	A	B1	B2	C1	C2	D	E	F**	G**	H1***	H2***	L1*	L2	W***	X**
JB(X)1	4	18 <sup>3/8</sup>	18 <sup>3/8</sup>	8 <sup>1/4</sup>	14 <sup>3/8</sup>	7 <sup>1/4</sup>	11 <sup>7/16</sup>	18 <sup>15/16</sup>	5	15 <sup>11/16</sup>	11 <sup>3/8</sup>	26 <sup>5/8</sup>	36 <sup>15/16</sup>	21 <sup>7/8</sup>	13 <sup>3/4</sup>
JB(X)2	4	19 <sup>1/16</sup>	18 <sup>1/2</sup>	9 <sup>1/2</sup>	14	9 <sup>1/8</sup>	17 <sup>3/4</sup>	20	6 <sup>5/8</sup>	19	12 <sup>1/8</sup>	28 <sup>5/8</sup>	39 <sup>1/4</sup>	30 <sup>11/16</sup>	24 <sup>1/4</sup>
JB(X)3	4	19 <sup>15/16</sup>	19 <sup>9/16</sup>	15 <sup>5/16</sup>	19 <sup>1/4</sup>	11 <sup>1/4</sup>	23 <sup>1/4</sup>	26 <sup>15/16</sup>	8 <sup>5/16</sup>	22 <sup>1/2</sup>	14 <sup>3/4</sup>	38 <sup>1/4</sup>	48	36 <sup>3/4</sup>	29 <sup>1/2</sup>

\* Add 1/4" to Dimension L1 for heavy oil burners. Use Dimension L2 for alternate control cabinet location.

\*\* On units with FGR for NOx reduction, FGR valve will emerge from side of burner opposite blower motor.

\*\*\* Extra ground clearance & width may be required for the addition of FGR. Consult factory for details.

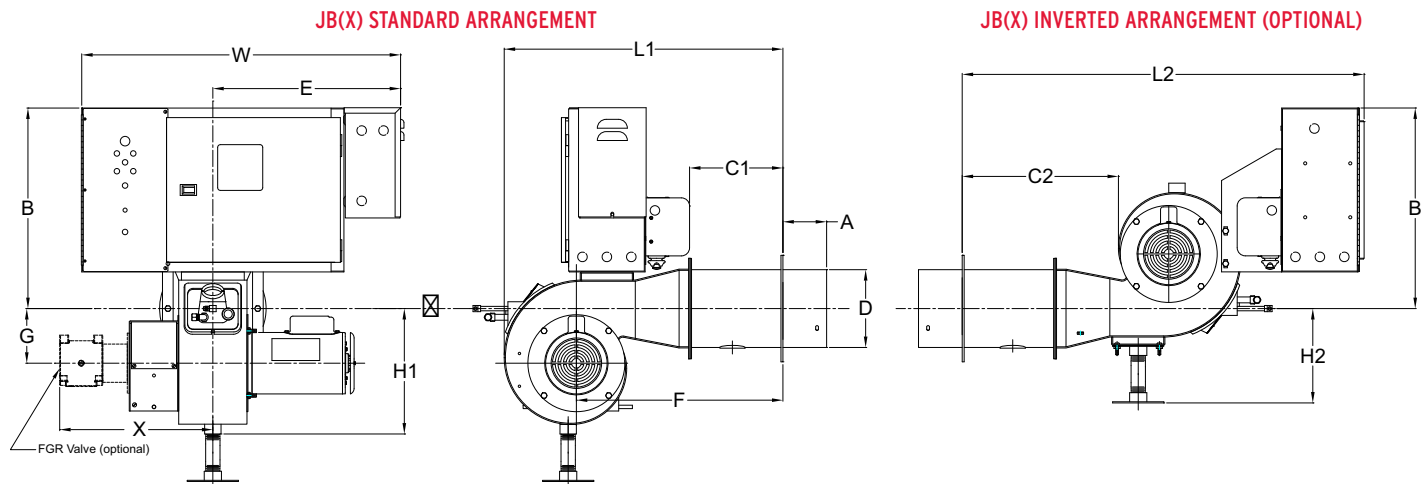

**The Better Boiler Burner.**

Represented By

619 Industrial Road, Winfield, KS 67156 / Phone: 620-221-7464 / Fax: 620-221-9447  
[www.webstercombustion.com](http://www.webstercombustion.com) / [sales@webstercombustion.com](mailto:sales@webstercombustion.com)